

# Worldwide Compliance

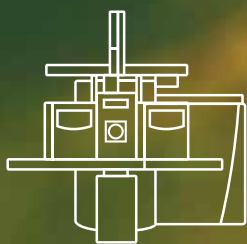

Setting the Gold Standard for Dioxin  
and POPs Analysis

Thermo Scientific DFS Magnetic Sector GC-HRMS

# Powering Dioxin and POPs analysis - around the world

The Thermo Scientific™ DFS™ Magnetic Sector GC-HRMS is the gold standard for performing Dioxin and Persistent Organic Pollutants (POPs) analysis. It empowers you to achieve full compliance with any official Dioxins, PCB, or PBDE method around the world.

For over a decade, the global scientific community has chosen Thermo Scientific DFS Magnetic Sector GC-HRMS for its superior performance in routine quantitative analysis of Dioxins and POPs. Today, the DFS Magnetic Sector GC-HRMS continues to set the gold standard in providing robust performance and high-confidence results.





### **Global compliance**

Contamination of food and the environment are global concerns. Both food import-export control and environmental analyses require compliance with numerous government and analytical methods. The DFS Magnetic Sector GC-HRMS is the only GC-MS compliant with any existing official methods and regulations, including US EPA, EU, and JIS methods.



### **Proven leadership**

Thermo Fisher Scientific is committed to providing solutions that enable our customers to lead in the analysis of Dioxins and POPs. With proven technology, the DFS Magnetic Sector GC-HRMS is the system of choice for experts who desire ultimate analytical confidence and routine reliability.



### **Ultimate confidence and robustness**

Failing to determine if samples are non-compliant or toxic can have serious consequences. You need to be sure of your analysis and the defensibility of your data. The DFS Magnetic Sector GC-HRMS provides robust, confident quantitation, down to very low femtogram levels.



### **Exceptional productivity and flexibility**

Labs face a wide array of sample loads and application demands. To meet these needs, the DFS Magnetic Sector GC-HRMS can be equipped with up to two Thermo Scientific™ TRACE GCs and four GC columns. Add the DualData XL Module to maximize sample throughput with up to twice as many injections per unit time compared to a single GC system. Multiple ionization modes and probe choices provide unmatched analytical flexibility.



### **Future committed**

Innovation and support for the DFS Magnetic Sector GC-HRMS are aimed at addressing emerging needs and new regulatory methods—today and into the future.



# Robust sensitivity

Based on magnetic sector technology, the DFS Magnetic Sector GC-HRMS performs Dioxin and POPs routine analysis, delivering ultimate confidence, no matter the sample type or matrix.

## Inlet and ion source

The robust-by-size large-volume ion source is designed for unparalleled sensitivity combined with durability. As a result, you get exceptional reliable performance. Less frequent ion source maintenance minimizes downtime.

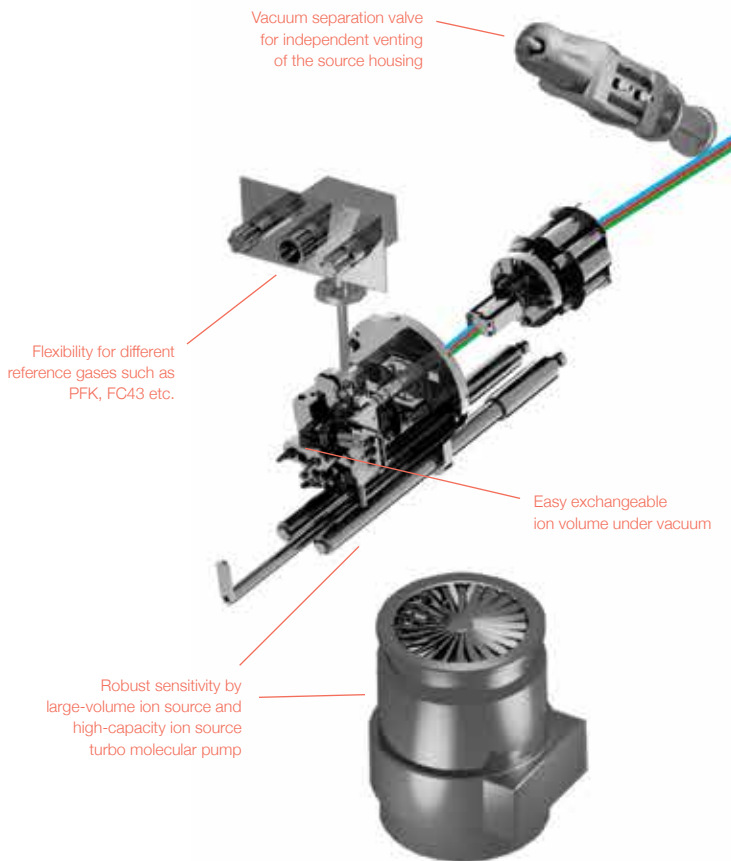
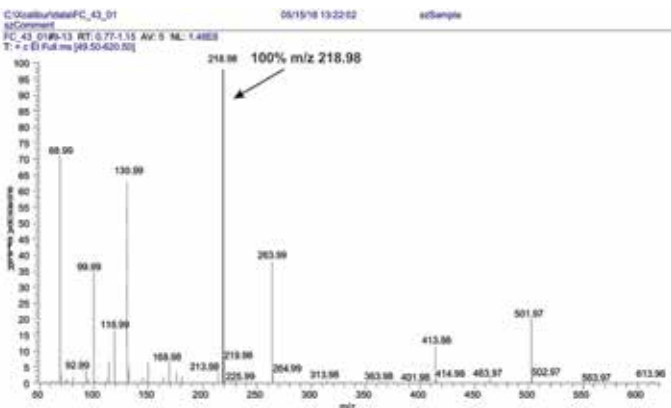

## Benefits of Magnetic Sector for Dioxins analysis

### Compliance with official methods

- Worldwide compliance with official Dioxin & POPs methods or regulations (e.g. EPA 1613).

### Confidence of analytical results

- Best Dioxin installation specification (based on 2378-TCDD with 4 sigma noise definition), shown during each DFS Magnetic Sector GC-HRMS installation.
- LOD/LOQ calculation using S/N real time detection limits calculated on each sample analysis.
- High linearity detection system and matrix independent calibrations.
- Automated mass calibration during each analysis run.

### Sensitivity combined with robustness for routine analysis

- Large-volume ion source for high sensitivity combined with maximum robustness.
- High capacity turbo pump for additional analytical robustness

### Real time traceability

- Lock mass trace for constant monitoring of the instrument stability and of the sample matrix effect, in compliance with official methods (e.g. EPA 1613).
- Proof for stable selectivity: mass resolution documented in log file with each analysis.

### Flexibility and productivity

- Unique dual GC configuration and optional multi-column installation (up to 4).
- Flexibility for reference gases, e.g. PFK (according to EPA 1613) or FC43, etc.
- DualData XL Option for almost doubled sample throughput.

### Ease of use and maintenance

- Exchangeable ion volume (inner ion source) without vacuum breaking for quick ion source maintenance.
- Separation valve for the individual venting of the ion source housing.

## A closer look inside the DFS Magnetic Sector GC-HRMS

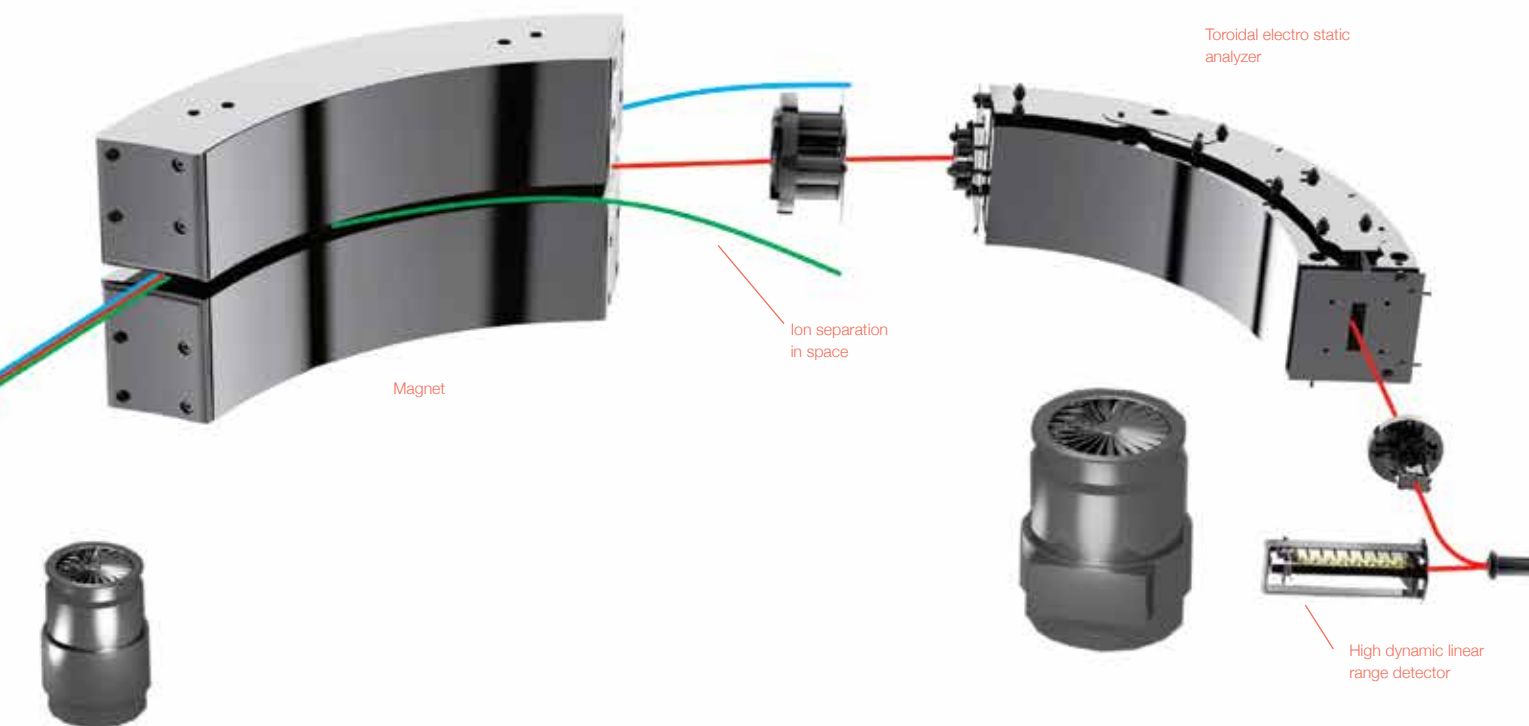

### Mass analyzer and detector

The magnetic sector analyzer is the first with virtually no image peculiarities. For optimal stability and ruggedness, it is perfectly double-focusing, with ultra-high-precision toroidal electrostatic and refined magnetic analyzers. The ion optics are robust, yet they enable high sensitivity, selectivity, and transmission of high masses.

### Dedicated software for smooth daily operation

Be compliant with any official regulation or method for Dioxin and POPs analysis with the dedicated software solution. Proven Thermo Scientific™ TunePlus software and dedicated DFS Magnetic Sector GC-HRMS software enable smooth daily operation for ease-of-use and straightforward method set-up. The tailored Dioxin software package for data evaluation allows you to fulfill all isotope dilution quantifications and all other requirements.

### Unique Magnetic Sector features

- Ion separation in space
- Mass-independent resolution: homogeneous analytical selectivity across the entire mass range
- Consistent sensitivity: good transmission for high masses (e.g. BDE-209)
- Consistent spectra



# Full application flexibility for food safety and environmental protection.

The gold standard in confident, ultra-trace routine quantitation, the DFS Magnetic Sector GC-HRMS can be used for any Dioxin and POPs application, and delivers sensitivity and high matrix tolerance. Complete worldwide compliance ensures you can keep up with global regulatory requirements.

## Environmental protection

Around the world, environmental threats continue to evolve, and compliance standards and regulations along with them. Persistent organic pollutants (POPs) analysis requires sensitive and selective workflows that facilitate compliance with official methods.

The DFS Magnetic Sector GC-HRMS enables laboratories to rapidly separate and quantitate contaminants in complex environmental samples down to femtogram levels. Even difficult sample types with heavy matrix effects can be successfully analyzed. The reliability, sensitivity, and robustness of the DFS Magnetic Sector GC-HRMS deliver dependable results that withstand examination.

Find out more at:

[thermofisher.com/GoldStandard](http://thermofisher.com/GoldStandard)





## Food safety

Food quality and safety are two of the most challenging issues in the current regulatory environment. Increasingly lower levels of dioxins in food, feed, and tissues mean that more selectivity and sensitivity are required to confirm their presence. No laboratory wants to risk their reputation reporting false negatives or false positives. The DFS Magnetic Sector GC-HRMS is the ideal system for this application. With defensible confirmatory quantitation of organic contaminants down to the very low femtogram levels, you can perform food safety analysis with confidence.

Application	Regulation/Norm	DFS Magnetic Sector GC-HRMS
Food safety	EU Regulatory Feed Control (at ML)	Approved
Food safety	EN 16215	Approved
Food safety	Background food studies (<1/5th EU ML)	Recommended by EURL
Clinical research	Human studies at trace levels	Recommended by EURL
Environmental	EN 1948	Approved
Environmental: Dioxins and Furans	US EPA 1613 B for strict EPA compliance	Approved
Environmental: PBDEs	US EPA 1614	Approved
Environmental	US EPA Method 23	Approved
Environmental	US EPA Method 8290	Approved
Environmental: PCBs	US EPA Method 1668	Approved
Environmental: Pesticides	US EPA Method 1699	Approved
Environmental: Hormones and steroids	US EPA 1698	Approved
Environmental	JIS K0311	Approved
Environmental	JIS K0312	Approved

# Tailored solutions for your analytical demands

For over a decade, the global scientific community has chosen Thermo Scientific DFS Magnetic Sector GC-HRMS for its superior performance in routine quantitative analysis of Dioxins and POPs. Today, the DFS Magnetic Sector GC-HRMS continues to set the gold standard in providing robust performance and high-confidence results.

## Standard configuration



Full performance for analysis of Dioxins and other POPs.

## Flexibility configuration



Unique double-GC configuration for maximum flexibility. For example PCDD/F on GC one and PCBs on GC two.

## Productivity configuration



Exclusive DualData XL Option based on double-GC configuration, for almost doubled sample throughput.

Find out more at: [thermofisher.com/DFS](http://thermofisher.com/DFS)

© 2018 Thermo Fisher Scientific Inc. All rights reserved. All trademarks are the property of Thermo Fisher Scientific and its subsidiaries. The information and technical specifications are subject to change without notice. Product availability may vary from country to country. Please contact your local sales representative for more information. **BR30476-EN 0118S**

**禹重科技® UZONGLAB**

分析仪器 | 实验方案 | 测试咨询 | 计量检定

上海市闵行区春申路2525号芭洛商务大楼  
电话：021-8039 4499 传真：021-5433 0867  
上海|北京|沈阳|太原|长沙|广州|成都|青岛|香港  
全国销售和售后服务电话：400-808-4598

邮编：201104, China  
邮箱：shanghai@uzong.cn

更多信息请访问：www.uzong.cn

**ThermoFisher**  
SCIENTIFIC



了解我们



微信公众号